

HIGHLY ACCURATE CALIBRATION SYSTEM FOR ELECTRONIC INSTRUMENT TRANSFORMERS

Yue Tong¹⁾, Guoxiong Ye¹⁾, Keqin Guo¹⁾, Hongbin Li^{1,2)}

1) State Grid Electronic Power Research Institut

2) Huazhong University of Science & Technology, Institute of Electrical & Electronic Engineering, Chian (✉ cherry8386@126.com)

Abstract

A high accurate electronic instrument transformer calibration system is introduced in this paper. The system uses the fourth-order convolution window algorithm for the error calculation method. Compared with Fast Fourier Transform, which is recommended by standard IEC-60044-8 (Electronic current transformers), it has higher accuracy. The relative measuring errors caused by asynchronous sampling could be reduced effectively without any special hardware technique adopted. The results show that the ratio error caused by asynchronous sampling can be reduced to 10^{-4} , and the phase error can be reduced to 10^{-3} degrees when the deviation of frequency is within ± 0.5 Hz. The present method of measurement processing is achieved by a high-accuracy USB multifunction data acquisition (DAQ) card and virtual measurement devices, with low cost, short exploitation period and high stability.

Keywords: Electronic instrument transformers, Digital output, Calibration system, Virtual instrument, Fourth-order Convolution Window

© 2011 Polish Academy of Sciences. All rights reserved

1. Introduction

As is well known, electronic transformers have been used in power systems because of their advantages of wide dynamic range, small size and adaptability for the development of digitization. As one of the most important equipments in power system, the accuracy of transformers is the basic guarantee for the metering, protection, monitoring and analysis of the power system. Take electronic instrument current transformers for example, according to the existing standards [1, 2], the electronic instrument current transformers for metering are classified into six classes: 0.1, 0.2, 0.5, 1, 3, 5; special purpose used instrument current transformers are classified into 0.2 s and 0.5 s. The ratio error and phase error in 1 % of rated current are also demanded. The accuracy of a relevant calibration system must be two grades higher. It means that the error of the calibration system must be less than 0.02 % for ratio error and 2' for phase error. Therefore highly accurate calibration of electronic transformers is very necessary. The requirement of electronic instrument voltage transformers is quite the same [3].

There are three main error sources of calibration system: the standard CT/VT, the digital sampling system and the error calculation method. Using the conventional CT and VT as standard transformer is easy to achieve a high accuracy, where the uncertainty is less than 0.01% for the ratio error and 0.3' for the phase error. The error of the digital sampling system includes two parts. One is the quantization error of the A/D converter and the other is the synchronous sample error. This system uses a NI 6281 for the digital sampling system. NI (National Instrument) Multifunction Series high-accuracy USB data acquisition (DAQ) devices are optimized for high accuracy at fast sampling rates with an outside trigger sample. The last and most important part of the main error resource is the error calculation method.

The electronic apparatus and high voltage equipment are widely used in the power system which causes harmonic and inter-harmonic distortion in the power line. According to IEC-60044-8, the range of standard frequency is 99 % fr ~101 % fr (fr is the rated frequency for metering), that is from 49.5 Hz to 50.5 Hz, when the rated frequency is 50 Hz. Even if the sampling frequency satisfies the Nyquist sampling criterion, the “classic” FFT, which is recommended by standard IEC-60044-8, cannot avoid the long-range spectral leakage, caused by an asynchronous sample. There must be some special signal processing for error calculation to meet the high accuracy requirement.

In this paper, a highly accurate calibration system using a multifunction USB data acquisition card for the digital sampling system and a virtual instrument achieving the fourth-order convolution window of DFT (Discrete Fourier Transform) algorithm is presented. Labview is used as the unified software platform for computing, storage, calling, and displaying. The form of virtual instrument that “software is machines” provides a convenient way for the present calibration system [4].

2. PRINCIPLE OF OPERATION

The block diagram of the calibration system is shown in Fig. 1. The calibration system consists of a standard transformer, a digital sampling system (DDS) and calibration software. The calibrated ECT/EVT consists of primary converter, secondary converter (SC) and MU (merge units) with the digital output from Ethernet. A sampling sync circuit (SSC) is used for two signal synchronous sampling the output from DDS and MU respectively.

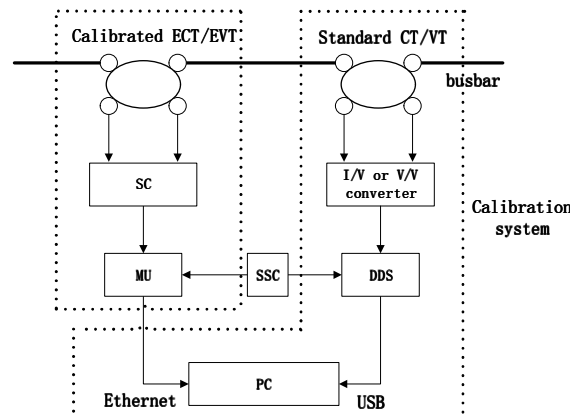

Fig.1 Block diagram of the calibration system for ECTs/EVTs

2.1. Standard CT/VT

The conventional CT/VT is used as the standard transformer in this system. It can be easy to achieve a high accuracy of uncertainty less than 0.01% for ratio error and 0.3' for phase error. With the I/V or V/V converter, the signal output from the standard CT/VT can convert into a voltage signal in order to appropriately access to the DDS.

2.2. Digital sampling system

The presented DDS is a high accuracy USB multifunction data acquisition (DAQ) card, NI-USB6281. The analog input is at 18-bits, 625 kS/s. Combined with advanced external synchronization and isolation it can start sampling under the external trigger. This high-accuracy device for USB delivers high-performance data acquisition in an easy-to-use and

portable form factor through USB ports on a personal computer and other portable computing platforms.

The 18-bit analog-to-digital converter (ADC) and available filtering provide an increase in resolution and higher measurement sensitivity. With fast sampling rates and a low noise floor, these devices can accurately acquire a dynamic signal.

2.3 Method of error calculation algorithm

The asynchronous sample caused by grid frequency fluctuation, results in leakage of the spectrum. A fundamental method of reducing long-range spectral leakage is selecting an appropriate window for sampling sequences. Some famous windows have been widely used, for example, a rectangular window, Hanning window, Blackman-Harris window, Rife-Vincent window and so on. In periodic signal measurement, the yardstick of windows is: minimum main lobe width, rapid side lobe attenuation. In recent years a new type of window has been raised – the convolution window. The convolution window is a kind of windows which is constructed by convolutions via a few rectangular windows with same time width. When the sampling synchronous deviation is slight, just as the power network fluctuation, the convolution window is better than the other famous windows in decreasing the error of the asynchronous sample [5-9].

Rectangular window function and its Fourier transform are as follows:

Rectangular window with time width T_0 can be written as:

$$w_1(t) = \frac{1}{T_0} \text{rect}\left(\frac{t}{T_0}\right) = \begin{cases} 1/T_0 & |t/T_0| \leq 1/2 \\ 0 & |t/T_0| > 1/2. \end{cases} \quad (1)$$

The Fourier transform of a rectangular window is given by:

$$W_1(f) = \int_{-\infty}^{\infty} w_1(t) e^{-j2\pi ft} dt = \text{sinc}(T_0 f) = \frac{\sin(\pi T_0 f)}{\pi T_0 f}. \quad (2)$$

The k-th order convolution window $W_k(t)$ is defined as the convolutions of k rectangular windows with width T_0 :

$$w_k(t) = w_1(t) \cdot w_1(t) \cdot \dots \cdot w_1(t). \quad (3)$$

According to the law of convolution, the Fourier transform of a k-th order convolution window in the frequency domain is given by:

$$W_k(f) = [\text{sinc}(T_0 f)]^k = \left[\frac{\sin(\pi T_0 f)}{\pi T_0 f} \right]^k. \quad (4)$$

The higher order window can accelerate the attenuation of the side lobe and it improves the precision of DFT. On the other hand, the width of the main lobe is increasing, which reduces the spectrum resolution. According to the needs of the calibration system, a fourth-order convolution window is chosen in this paper.

Omitting the process of derivation, the fourth-order convolution window expression in the time domain is presented to be:

$$w_4(t) = \frac{1}{3!T_0} \begin{cases} 0 & x \geq 2 \\ (2-x)^3 & 1 \leq x < 2 \\ (2-x)^3 - 4(1-x)^3 & x < 1 \end{cases}, \quad (5)$$

where $x = |t/T_0|$.

The accuracy of the algorithm is affinitive to the zero point value of the window function. And the fourth-order convolution window's third-order derivative is zero, which means that the fourth-order convolution window has an excellent performance in harmonic analysis and frequency fluctuation.

2.4. Design of calibration software

The calibration system based on virtual instrument replaces the traditional calibrator with personal computer. That is easy to use, graphical user interface to programmer remarkably shortens exploitation period and reduces the need for high level in language programming and debugging. The Labview is multithreading and multitasking program. The main flow chart is shown in Fig. 2. The whole program includes receiving data from DAQ and network adapter, digital signal processing and error calculation [10].

Data from standard transducer is sampled by DAQ provided in Labview through NI-USB6281. It can be called expediently to specify the parameters like sample rate, samples to read and sample start with trigger. Receiving data from calibrated transducer through MU is much more complicated. The output interface of electronic instrument transformers is based on IEEE 802.3, which is beyond the offer of the Labview existing module. It needs an external dynamic link library with WinPcap function to achieve this task.

The digital signal processing program is the core of the whole system. It achieves the fourth order convolution window algorithm whose time domain expression is proposed above. Then the samples are multiplied by the windows in time domain. Through discrete Fourier transform the parameters of fundamental frequency signal such as altitude and phase can be abstracted in frequency domain.

Finally, the ratio error and phase error are calculated. The calculation results and signal waves are presented in front panel, while the program is presented in back panel. And the software also can do storage, playback, and document management.

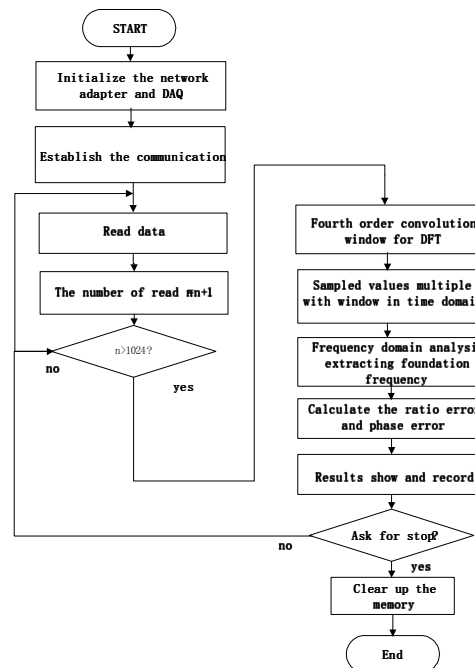

Fig. 2. The flow chart of software

3. EXPERIMENT

The first experiment is to verify that the fourth-order convolution window of the DFT algorithm can obtain a more accurate representation of error estimate of electrical parameters. This experiment is simulated in Labview, using a virtual signal generator to simulate the output of an electronic instrument transformer. Generally speaking, the fluctuation of frequency in the grid is caused by harmonics. The odd harmonic is more harmful than the even harmonic. In a balanced three-phase system, the even harmonic is cancelled and only the odd harmonic left. So in this experiment, a signal with the 3rd, 5th, 7th harmonic is simulated as the resource. The simulation resource in Labview is shown in Table 1:

Table 1 The simulation resource

Harmonic order	1	3	5	7
Amplitude(V)	100	30	20	10
phase(°)	0	20	130	150

Under the same conditions that the sample rate is 6.4 kHz, the sampling number is 1024, and the simulation result is shown in Table 2

Table 2 The measuring error of harmonic test

Window function	Harmonic order			
	A1(%)	A3(%)	A5(%)	A7(%)
Blackman-Harris	2.45E-4	1.74E-4	7.12E-5	4.12E-4
fourth-order convolution window	3.14e-8	5.11e-6	1.45e-6	1.37e-6
	ϕ 1(°)	ϕ 3(°)	ϕ 5(°)	ϕ 7(°)
Blackman-Harris	4.87E-4	2.16E-4	2.56E-5	3.42E-4
fourth-order convolution window	1.86E-8	2.12E-6	8.45E-7	5.68E-6

The regular harmonic simulation result shows that the fourth-order convolution window algorithm can reduce the harmonic calculation error effectively.

The second experiment is confirming the error caused by asynchronous sampling with a frequency fluctuation from 49.5 Hz to 50.5 Hz. It is carried out by comparing two algorithms with the same resource whose frequency varies from 49.5 Hz to 50.5 Hz in the same amplitude and phase. The result is shown in Table 3:

Table 3 The measuring error of frequency fluctuation test

Window function	Frequency				
	A49.5(%)	A49.8(%)	A50(%)	A50.2(%)	A50.5(%)
Blackman-Harris	-0.18	-0.08	0	-0.06	-0.26
fourth-order convolution window	-3.85E-4	-4.26E-5	0	-2.46E-5	-2.7E-4
	ϕ 49.5(°)	ϕ 49.8(°)	ϕ 50(°)	ϕ 50.2(°)	ϕ 50.5(°)
Blackman-Harris	-0.27	-0.09	0	-0.073	-0.25
fourth-order convolution window	-7.5E-3	-2.5E-4	0	-1.75E-4	-8.3E-3

Furthermore, another experiment is taken to compare with the calibration system in the State Grid Electric Power research Institute (SGEPI), where the highest national standard is established. A sample electronic instrument transformer is tested under two calibration systems. The sample electronic instrument transformer is a Gas-Insulated Metal-Enclosed Switchgear (GIS) 220 kV combined voltage and current transformer. The current transformer

is of class 0.2 s, and the voltage transformer is class 0.1 for metering and class 3P for protecting.

The results are shown in Fig. 3 and Fig. 4. Two groups of test data show basic coincidence.

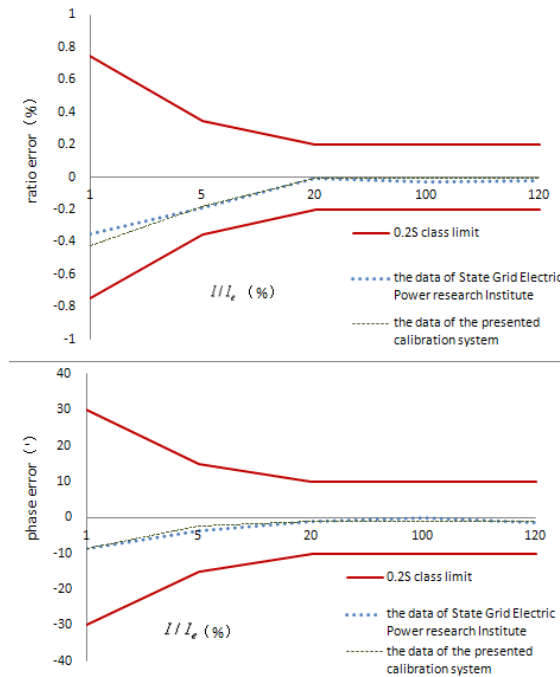

Fig.3 The normalized ratio error and phase error results of the current transformer comparison tests

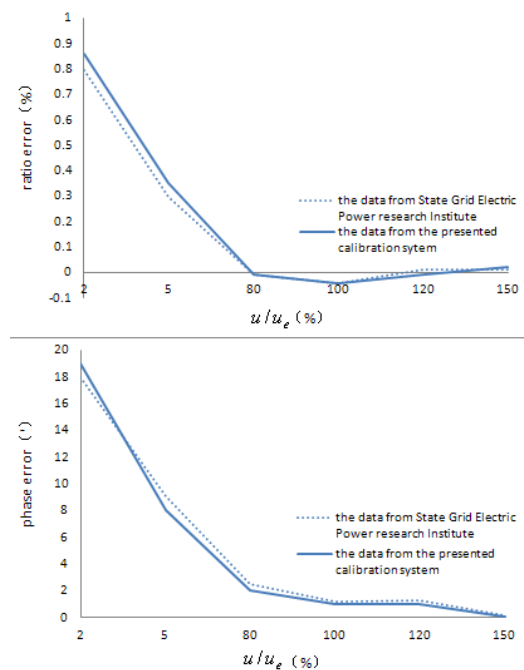

Fig.4 The normalized ratio error and phase error results of the voltage transformer comparison tests

4. Performance evaluation

Every segment of the calibration system is traceable. The standard CT/VT uncertainty can be measured by comparing with a much more accurate reference transducer. The DDS, the

NI-USB-6281 device also has a two-year calibration interval in NI company services to help maintain the ongoing accuracy of the measurement hardware.

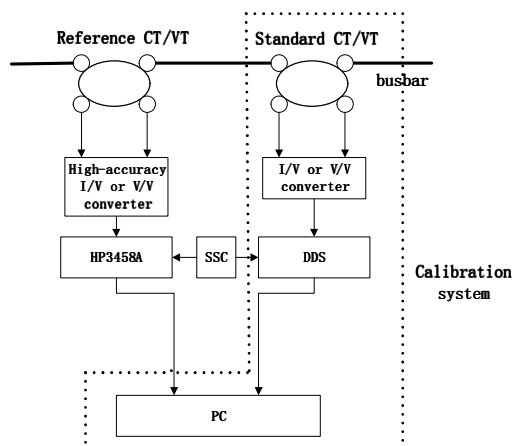

Fig.5 Block diagram of the test setup for verification of the calibration

Besides that, the calibration system can be evaluated in a laboratory too. The block diagram of the test setup is shown in Fig. 5. The test set includes a reference CT/VT, high-accuracy I/V or V/V converter and HP3458A. The reference CT/VT and the high-accuracy converter must be of at least few times higher accuracy than the standard CT/VT and I/V or V/V converter tested. A precise digital voltmeter HP3458A is used as a reference A/D converter which is used in numerous high precision measurements. It provides an effective precision of 24 bits with the least significant bit weighted 2^{-23} . The error of the test setup is small enough to be ignored when it is used for verification of the calibration.

Under this test setup, the linearity of the presented calibration system limits in 0.02% for the ratio error and 1' in the phase error, when the dynamic range is from 1% $I_e \sim 120\% I_e$ (I_e is the rated current value) and from 80% $U_e \sim 120\% U_e$ (U_e is the rated voltage value). It is qualified to calibrate class 0.2 s electronic current instrument transformers and class 0.1 electronic voltage instrument transformers.

5. Conclusions

A high-accuracy calibration system for electronic instrument transformers is presented in this paper. A virtual instrument as a platform to achieve a fourth-order rectangular convolution window of the DFT algorithm can effectively reduce the measuring error caused by an asynchronous sample. The digital sampling system which is based on an USB data acquisition card can avoid the noise caused by hardware, and decrease the source of the measuring error. The system is portable and excellent in both flexibility and computing speed of digital signal processing as well. The realization with a virtual instrument is low fabrication costs and a short development cycle. This system has achieved a high accuracy of electronic instrument transformers measurement, which meets the requirement of calibrating class 0.2s electronic current instrument transformers and class 0.1 electronic voltage instrument transformers.

References

- [1] IEC60044-7. (2002). Instrument Transformers-part 7. *Electrical Voltage Transducers*.
- [2] IEC60044-8. (2002). Instrument Transformers-part 8. *Electrical Current Transducers*.

- [3] Naumovic-Vukovic, D., Skundric, S., Kovacevic, D., Milosavljevic, S. (September 2009) Calibration of high accuracy class standard current transformers. XIX IMEKO World Congress Fundamental and Applied Metrology. Lisbon.
- [4] Bilski, P., Winiecki, W. (2002). Virtual Spectrum Analyzer Based on Data Acquisition Card, *IEEE Transaction on instrumentation and measurement*, 51(1), 82-87.
- [5] Zhang Jieqiu, Liang Changhong, Chen Yanpu (2004). Power System Harmonic Theory Analysis and Algorithm Based on Convolution Windows. *Proceedings of the CSEE*, 21(11) , 48-52.
- [6] Nuttall, A.H. (1981). Some window with very good sidelobe behavior. *IEEE Trans. On ASSP*, 29(1), 84-91.
- [7] Zhao Fusheng, Geng Zhongxing, Ge Yaozhong (2001). FFT algorithm with high accuracy for harmonic analysis in the electric machine. *Proceedings of the CSEE*, 21(12), 83-87.
- [8] Harris, F.J. (1978). On the use of windows for harmonic analysis with the discrete Fourier transform. *Proc. IEEE*, 66(1), 51-83.
- [9] Jain, V.K., Collins, W.L., Davis, D.C. (1983). High-accuracy analog measurement via interpolated FFT. *IEEE Trans on Instrum. Meas.*, 32(6), 350-355.
- [10] Teng J.H., Chan S.Y. (2000). A Labview Based Virtual instrument for Power Analyzers. *IEEE Power System Technology*, (1), 179-184.